

## James Harriman – Input List (Solo)

1	Looper	DI	<p><b>Use This as The Main Bulk Of The Sound.</b> May Need Some EQ To Avoid Feedback, Please Do Not Cut The Low End</p> <p>James Has Control Of The Instrument/Vocal Levels on His Pedalboard, So Let Him Know If Anything Needs Changing</p>
2	Acoustic Guitar	DI (Provided By Us)	<p><b>Use As A Boost If Needed During Set</b></p> <p>This Will Have An Octave On Some Songs, Please Don't Cut The Sub Frequencies/Low End</p>
3	Vocal	XLR	<p><b>Use As A Boost If Needed During Set</b></p> <p>Will Come Through With FX So may need EQ In Line check</p>

## Output List (Solo)

1	In Ear Monitors (Provided By James)	Lot Of Looper, Small Amount Of Vocal And Acoustic Guitar	<p>Send Signal From Desk/Monitor Desk Or</p> <p>Send Signal Direct From Looper</p>
2	On Stage Monitor (Provided By Venue)	Acoustic Guitar, Vocal, No Looper	<p>Please Use A Stage Left Or Stage Right Monitor To Avoid Bleed On Looper Tracks</p>

## James Harriman Solo Pedalboard Setup –

All **Output** leads are marked with a **Blue**, **Yellow** and **Red** tag for easy Identification and come out of the **Left** side of the pedalboard. All **Input** leads go into the **Right** side of the pedalboard.

**Green** – Guitar Signal

**Yellow** – Looper Signal

**Orange** - Mic Signal

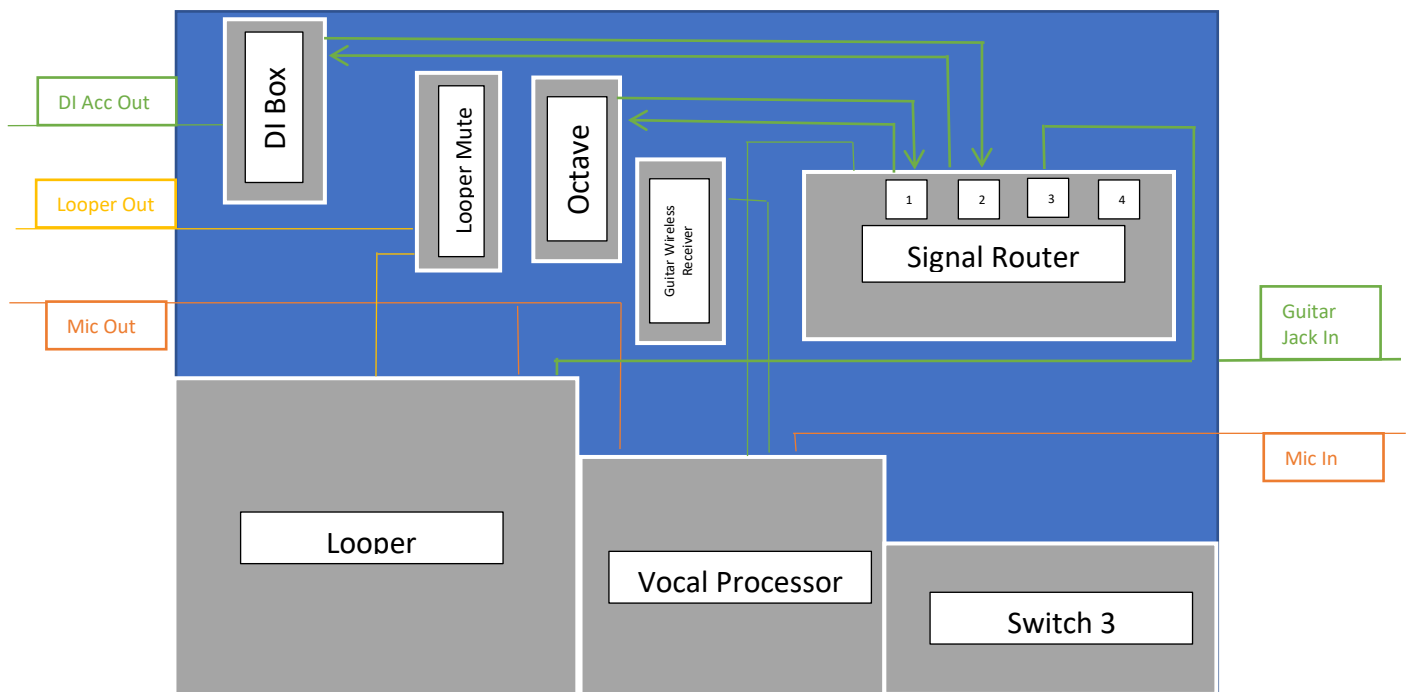

## Solo Set Stage Plan -

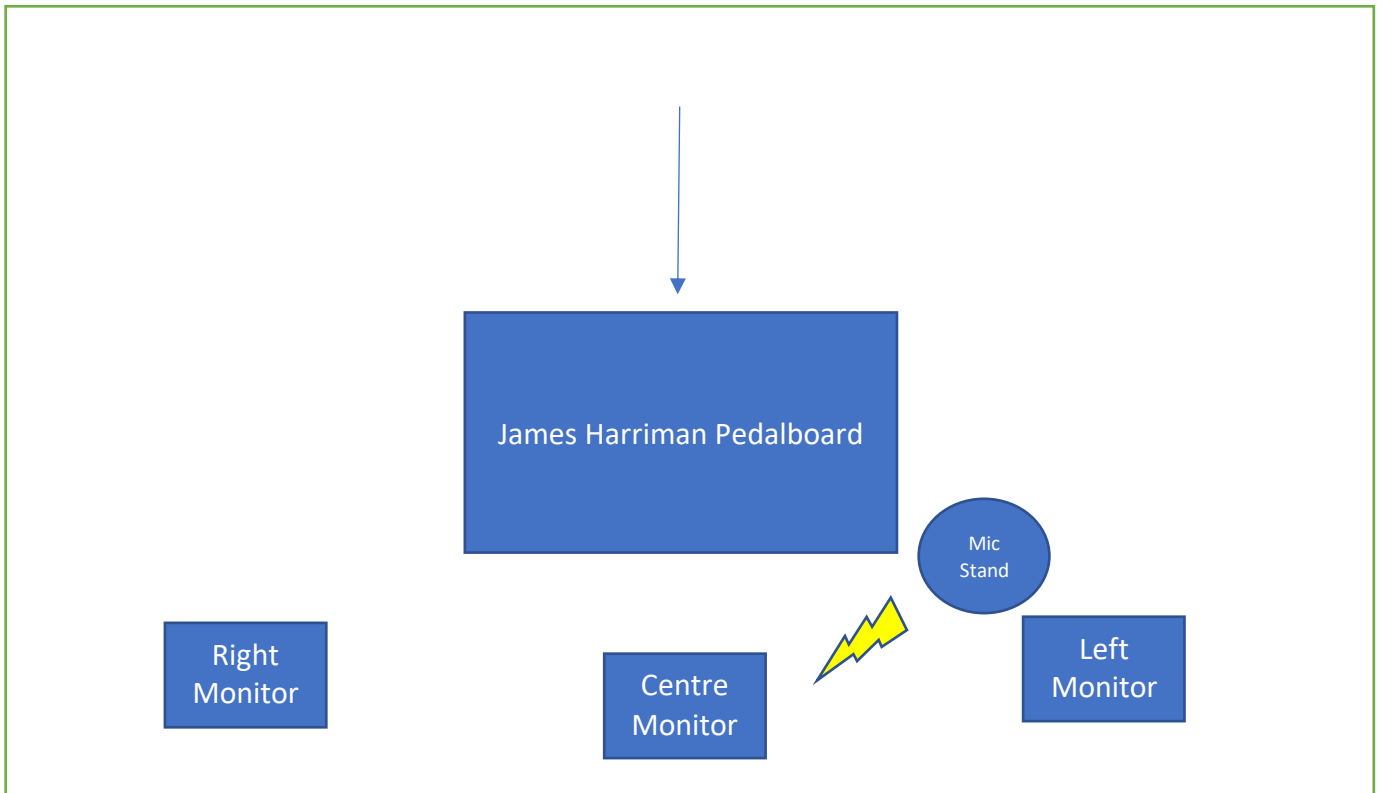

## Other Details –

Please ensure when possible that a boom mic stand is used and is positioned on the left side of the pedalboard, extended close to the centre of the pedalboard. In the event of rain please ensure that James' Pedalboard is out of the rain.

James requires two bottles of water to be placed on the right side of his pedalboard. When possible, James would like a glass of white wine or a can of larger to be placed nearby to toast with during his set.

If you need to contact James during the event you can reach him on his mobile 07907123133. If you need to contact James before the event please use this email - jamesharrimansinger@gmail.com